

# **Wire & Stealth Antenna**

Ozaukee Radio Club

Tom Ruhlmann (W9IPR)

# Resources

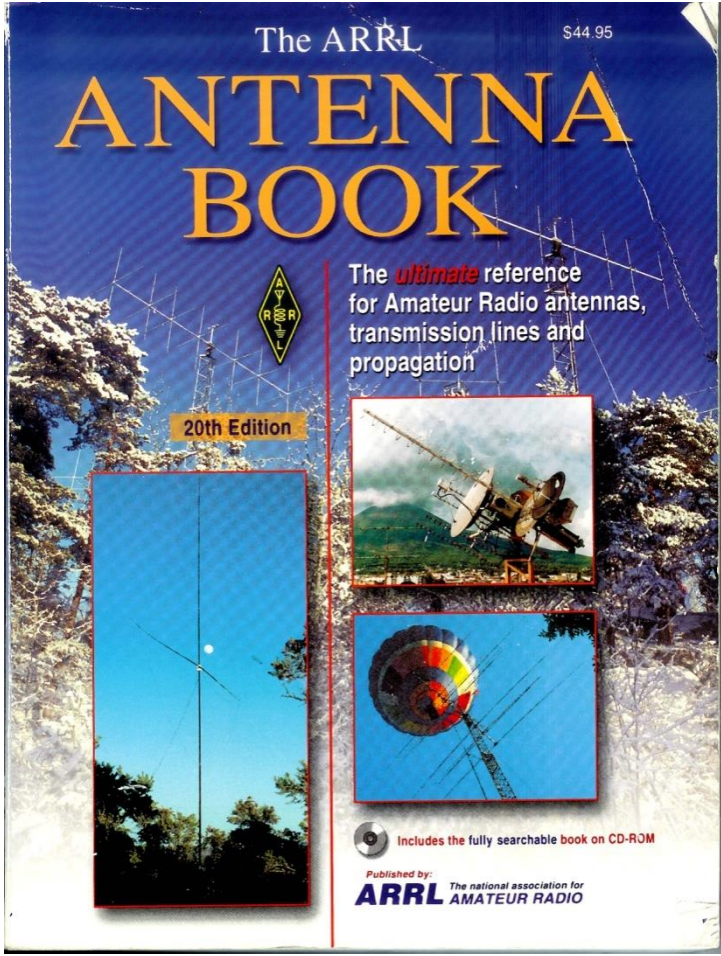
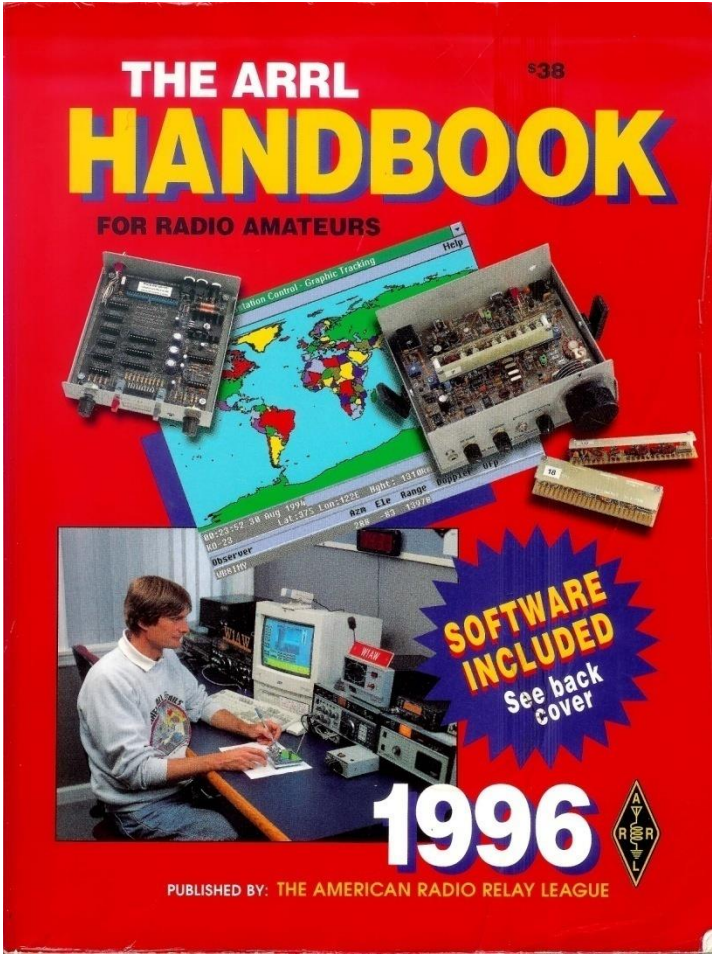

# Not Stealth!



# **Stealth ? It means the neighbors don't notice it.**

- Usually a wire on HF or
- Could be a beam on VHF & UHF
- May be a dual purpose radiator or
- May be too small to be noticed or
- May be inside the house or
- May be camouflaged or
- May simply be “out of sight”
- Ideally will be multiband

# Stealth – where's the antenna?



# 10, 15, 20, 40, 80 or 160 Meters?

$$\lambda_{\text{meters}} = \frac{299.7925 \times 10^6 \text{ meters/sec}}{f \text{ hertz}} = \frac{299.7925}{f \text{ MHz}} \quad (\text{Eq 1})$$

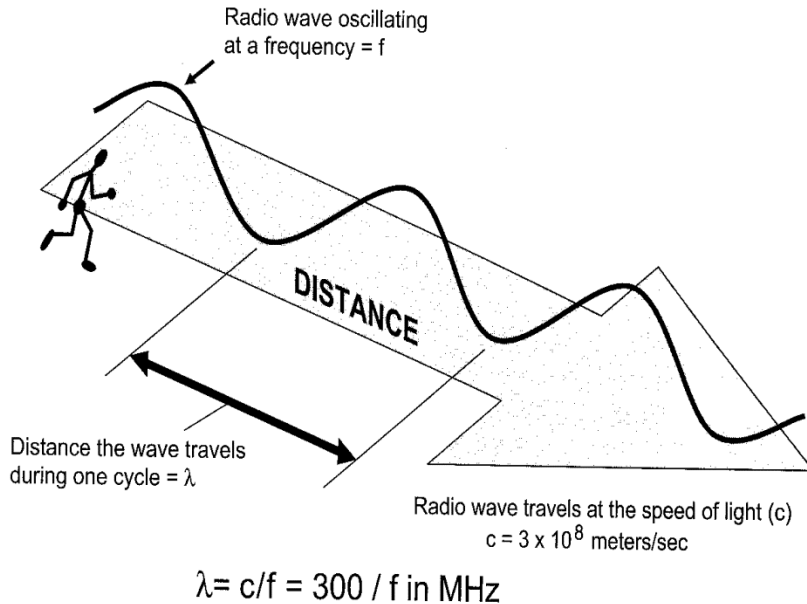

where  $\lambda_{\text{meters}}$ , the Greek letter lambda, is the free-space wavelength in meters.

Expressed in feet, Eq 1 becomes:

$$\lambda_{\text{feet}} = \frac{983.5712}{f \text{ MHz}} \approx \frac{983.6}{f \text{ MHz}} \quad (\text{Eq 2})$$

# Voltage (e), Current(i) and Impedance (z)

$z = e / i$  at the center feed point

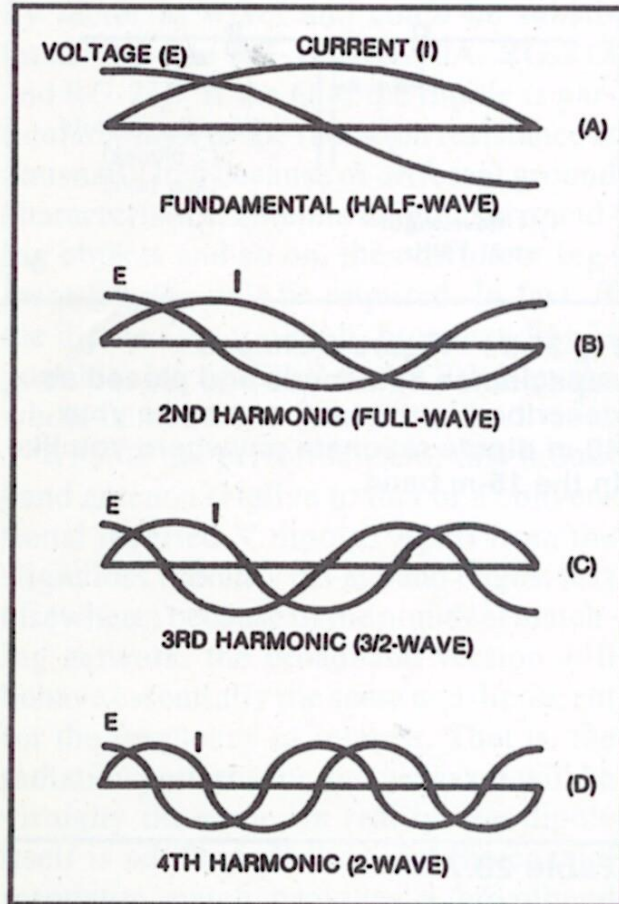

$$(A) z_{\min} = e_{\min} / i_{\max}$$

$$(A) z_{\max} = e_{\max} / i_{\min}$$

$$(A) z_{\min} = e_{\min} / i_{\max}$$

$$(A) z_{\max} = e_{\max} / i_{\min}$$

# Voltage (e), Current(i) and Impedance (z)

$z = e / i$  at the end feed point

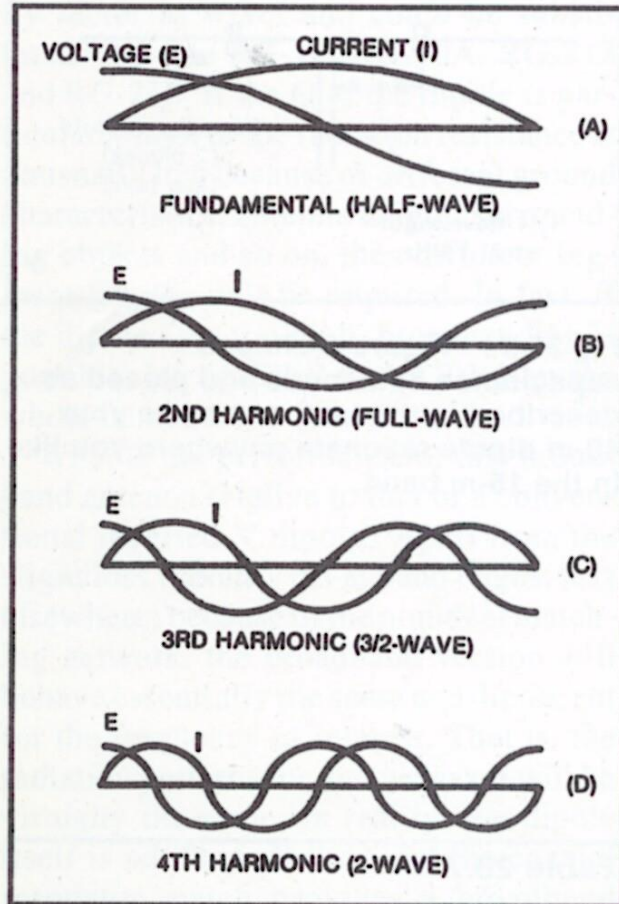

(A)  $z_{\max} = e_{\max} / i_{\min}$

(A)  $z_{\max} = e_{\max} / i_{\min}$

(A)  $z_{\max} = e_{\max} / i_{\min}$

(A)  $z_{\max} = e_{\max} / i_{\min}$



# Radiator Orientation & Polarization

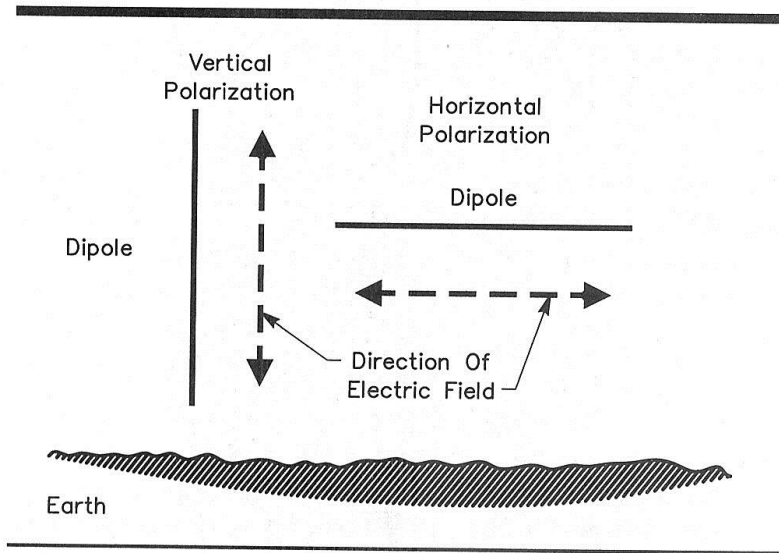

Fig 19—Vertical and horizontal polarization of a dipole above ground. The direction of polarization is the direction of the maximum electric field with respect to the earth.

2-14 Chapter 2

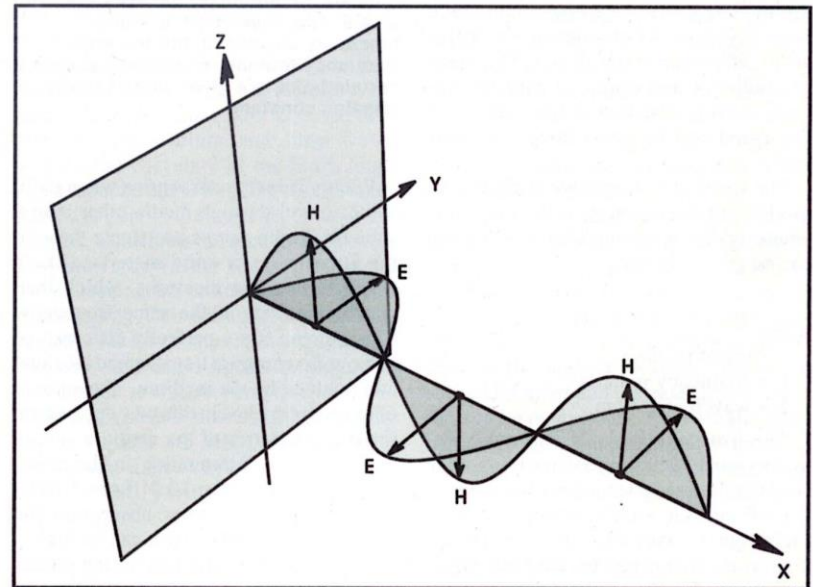

Fig 21.1—Electric and magnetic field components of the electromagnetic wave. The polarization of a radio wave is the same direction as the plane of its electric field.

# All Band Long Wire Antenna

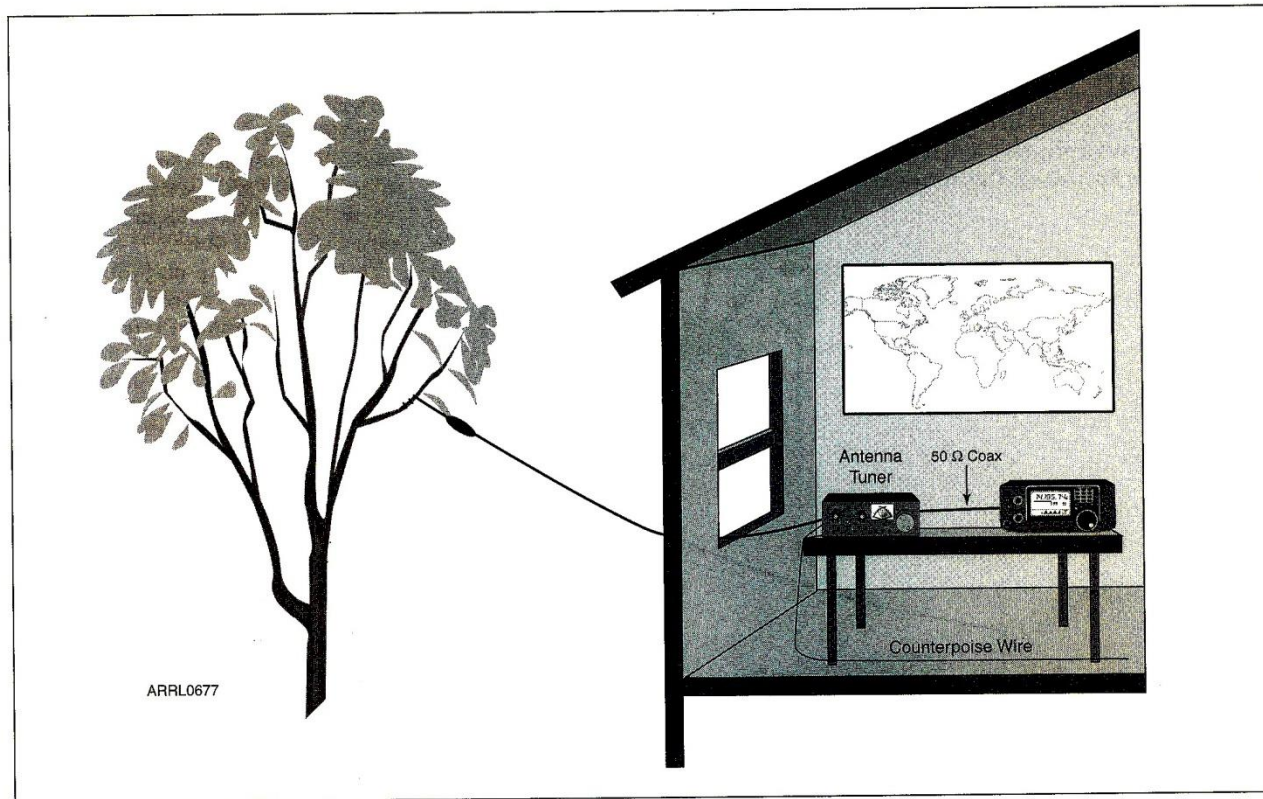
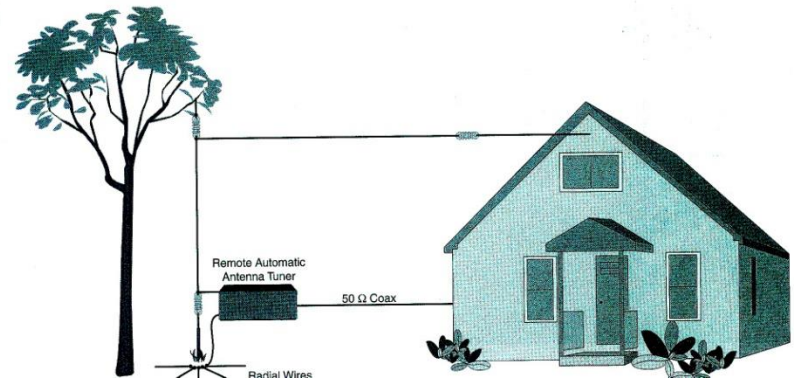
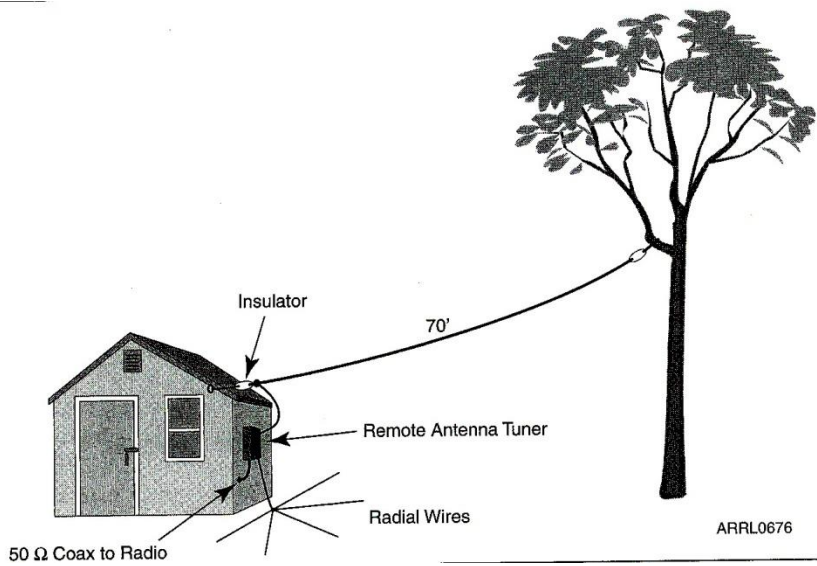

Figure 3.25 — An end-fed wire antenna can also be used by apartment or condo dwellers. The trick, however, is keeping the RF out of your equipment. To help prevent this, you'll need to attach an insulated counterpoise wire that is  $\frac{1}{4}$  wavelength at your lowest frequency. The wire can lie on the floor along the baseboards tucked behind furniture. Considering the RF voltage and exposure issues, it is best to use low power with an antenna of this type.

# Use a Remote Tuner



# Inverted L Wire Antenna

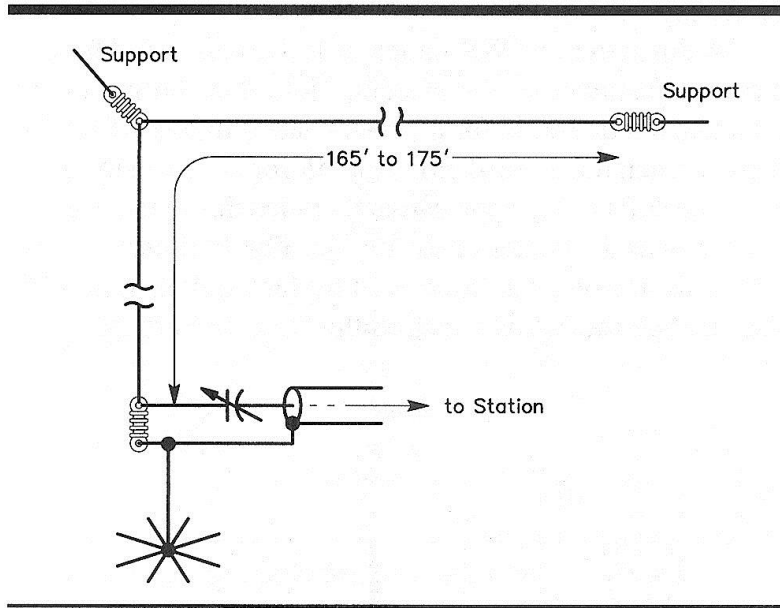

Fig 57—The 1.8-MHz inverted L. Overall wire length is 165 to 175 feet. The variable capacitor has a capacitance range from 100 to 800 pF, at 3 kV or more. Adjust antenna length and variable capacitor for lowest SWR.

6-32 Chapter 6

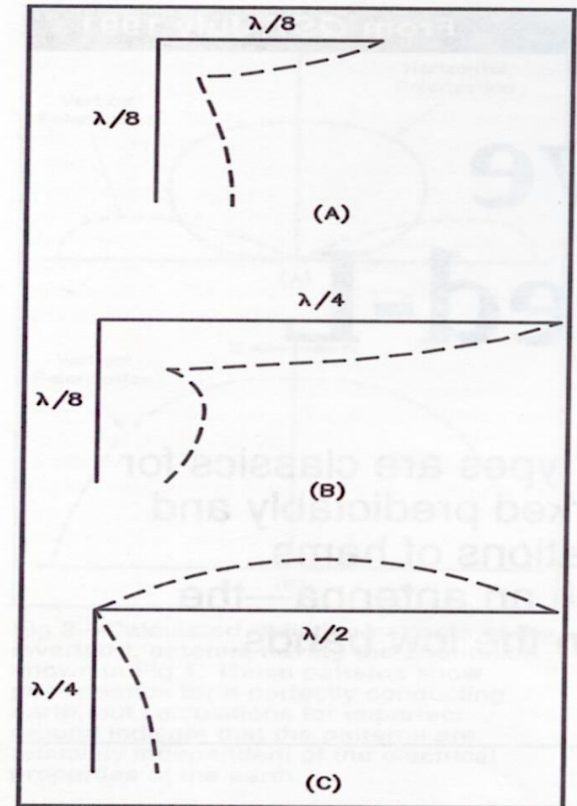
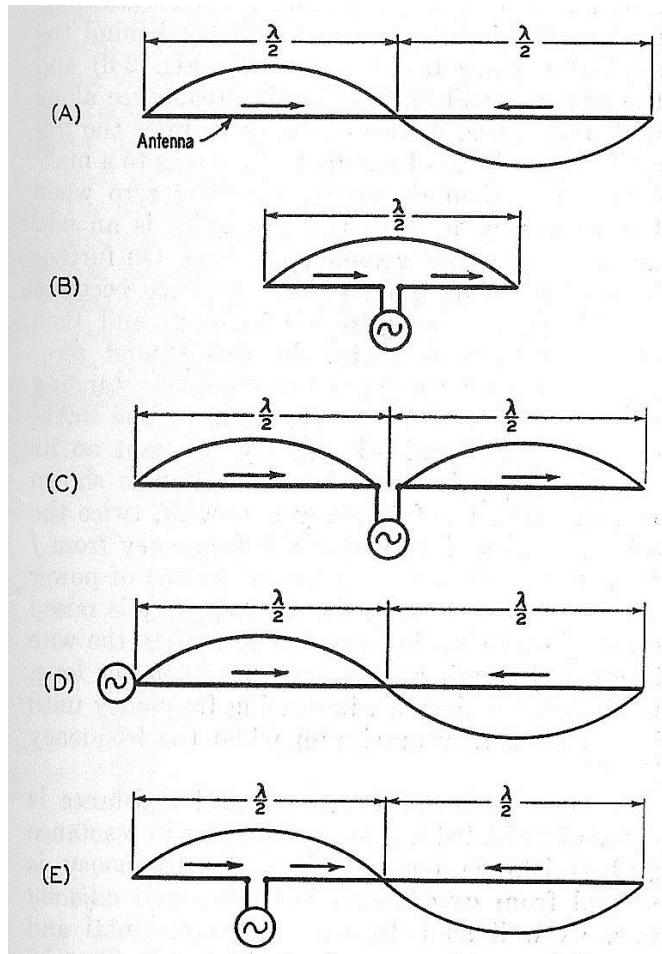

Fig 1—At A, the basic inverted L commonly used on the lower-frequency ham bands. The dotted line represents current distribution. The  $\frac{3}{8}$ -wavelength inverted L shown at B features a more favorable current distribution. At twice the fundamental (C), the antenna at B acts as a  $\frac{3}{4}$ - $\lambda$  wire. Note the two current maxima. The antenna behaves like a quarter-wave vertical end-feeding a half-wave dipole.

the pattern more closely resembles the pattern of a dipole at the same height. At twice the antenna's lower operating frequency, this antenna works best for short- and medium-distance contacts, but I've worked my share of DX with it, too.

# Full Wave Dipoles



# Dipoles

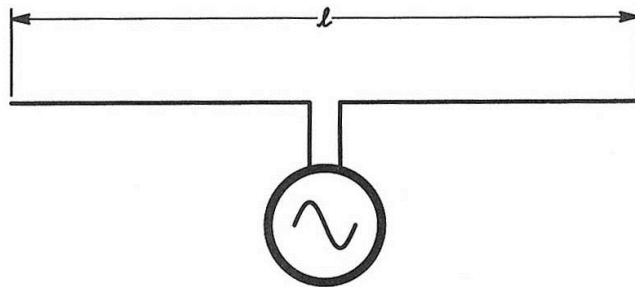

**Fig 1—The center-fed dipole antenna. It is assumed that the source of power is directly at the antenna feed point, with no intervening transmission line. Most commonly in amateur applications, the overall length of the dipole is  $\lambda/2$ , but the antenna can in actuality be any length.**

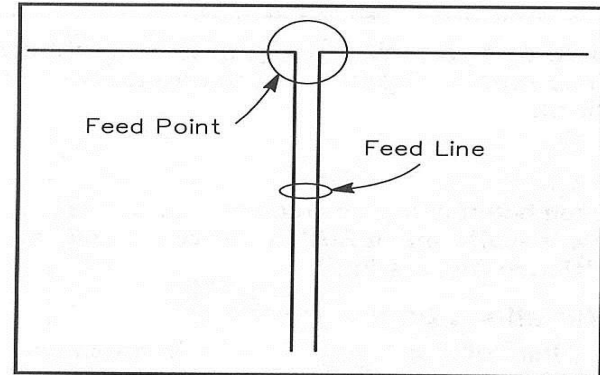

**Fig 1—One of the simplest antennas used by hams, the dipole is also one of the most effective, considering the relatively small space it requires. In its simplest form, a dipole is a wire fed at its center.**

**Table 1**

**Approximate Lengths of Half-Wave Dipoles for the MF/HF Ham Bands\***

<i>Frequency</i>	<i>Length</i>
28.4 MHz	16 ft, 6 in.
24.9 MHz	18 ft, 10 in.
21.1 MHz	22 ft, 2 in.
18.1 MHz	25 ft, 10 in.
14.1 MHz	33 ft, 2 in.
10.1 MHz	46 ft, 4 in.
7.1 MHz	65 ft, 11 in.
3.6 MHz	130 ft
1.8 MHz	260 ft

\*General equation for half-wave dipole length:  
 $\ell = 468 \div f$ , where  $\ell$  is length in feet and  $f$  is frequency in megahertz. This equation yields good starting points; you may have to lengthen or trim your antenna to achieve resonance. See the sidebar entitled "Dipole Construction and Adjustment."

# Fan Dipole

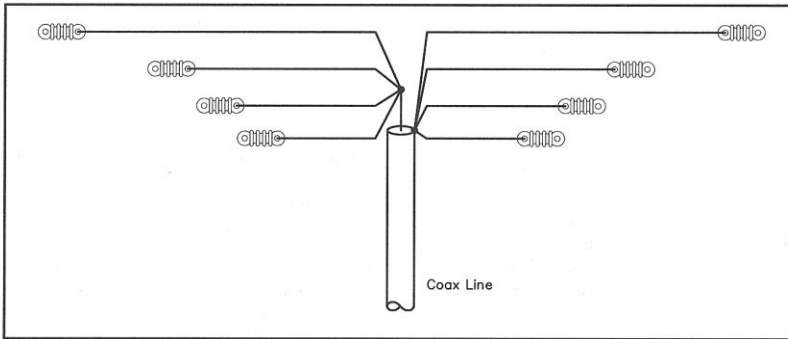

Fig. 1—Sketch showing the arrangement of parallel half-wave antennas in the coax-fed multiband antenna system.

Chapter 2 2-1

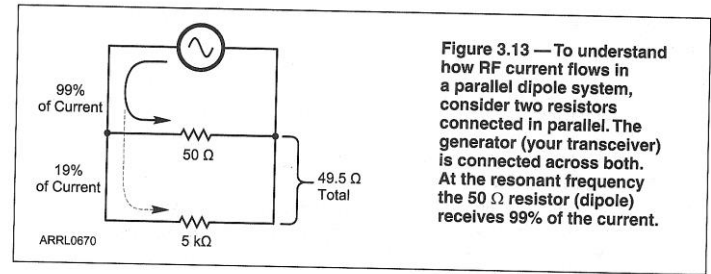

Figure 3.13 — To understand how RF current flows in a parallel dipole system, consider two resistors connected in parallel. The generator (your transceiver) is connected across both. At the resonant frequency the 50 Ω resistor (dipole) receives 99% of the current.

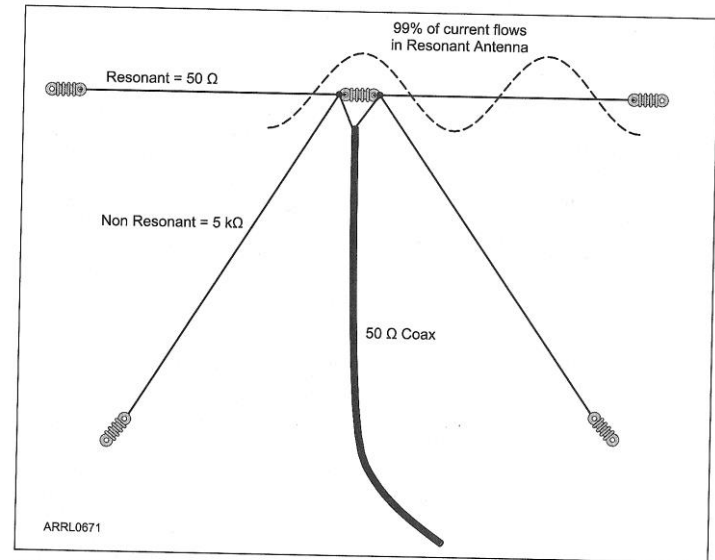

Figure 3.14 — A group of parallel dipoles behaves just like the parallel resistors in Figure 3.13. The resonant 50 Ω dipole receives most of the current.

# Shortened Antenna

(insert a coil to add length)





# Outside Stealth

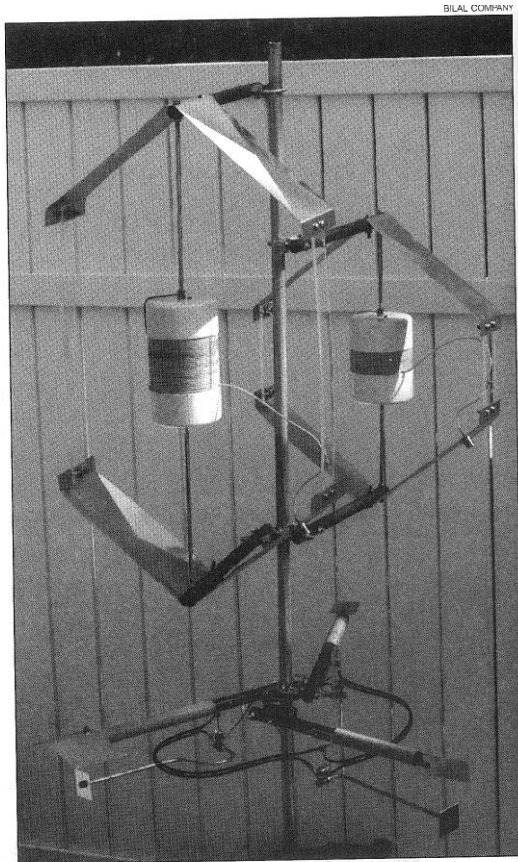

The Bilal Isotron antennas can be set up outdoors in either temporary or permanent installations. [www.isotronantennas.com](http://www.isotronantennas.com)

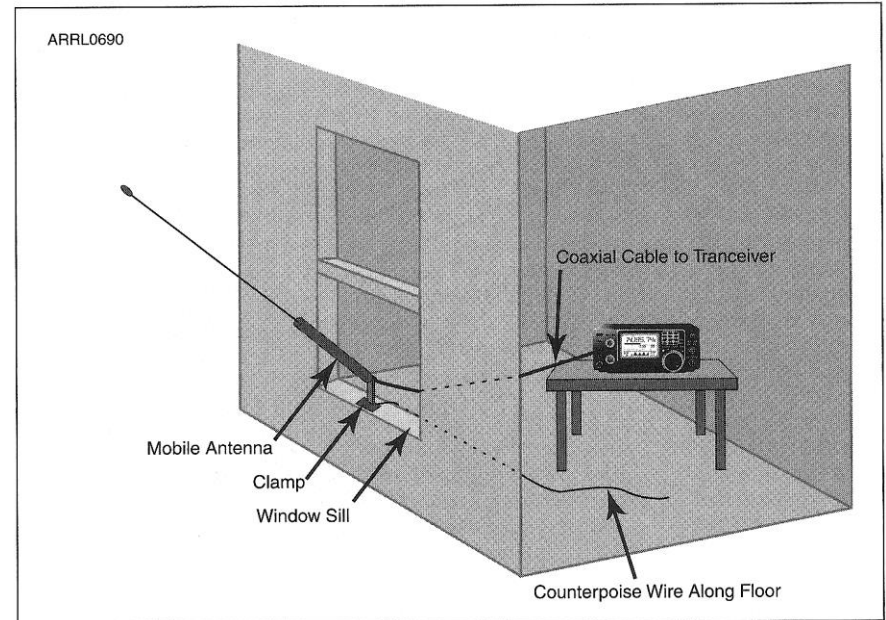

Figure 2.8 — A mobile antenna can clamp to a windowsill and extend outdoors. To provide an RF current “return,” a counterpoise wire attaches to the antenna ground point (where it would normally attach to a car body). This wire should be at least  $\frac{1}{4}$  wavelength at the desired frequency if the mobile antenna is a single-band design. If it is a multiband tunable antenna, it will work best with a  $\frac{1}{4}$  wave counterpoise for each band you intend to use.

# Dual Purpose Antenna

Tune the gutters



Fly the Flag

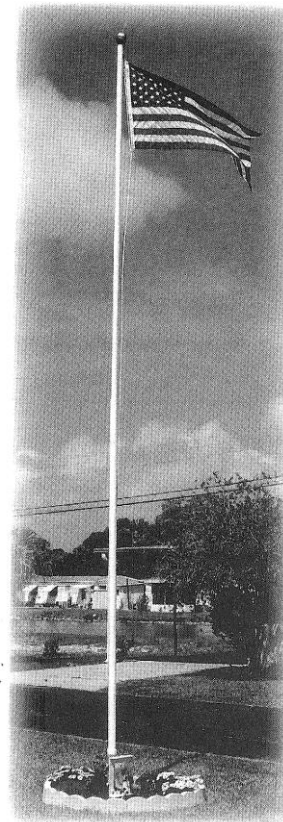

# Disguise the Outside Antenna

## A Weather Vane?

### A Weather Vane Antenna for 2 Meters

John Portune, W6NBC, and  
Fred Adams, WD6ACJ

*VHF incognito! Here's a  
2 meter antenna your  
neighbors won't recognize.*

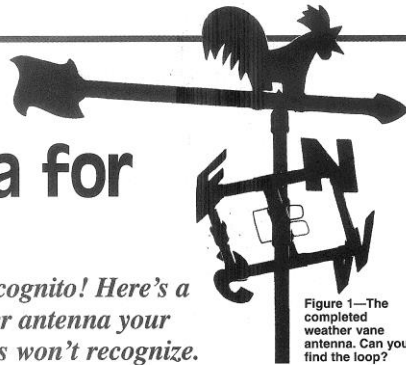

Figure 1—The completed weather vane antenna. Can you find the loop?

## A Vent Pipe ?



# Off Center Fed Multiband Dipole

Z at 1/3 point

Note  $z = e / i$  at 1/3 point

approximately 200 ohms

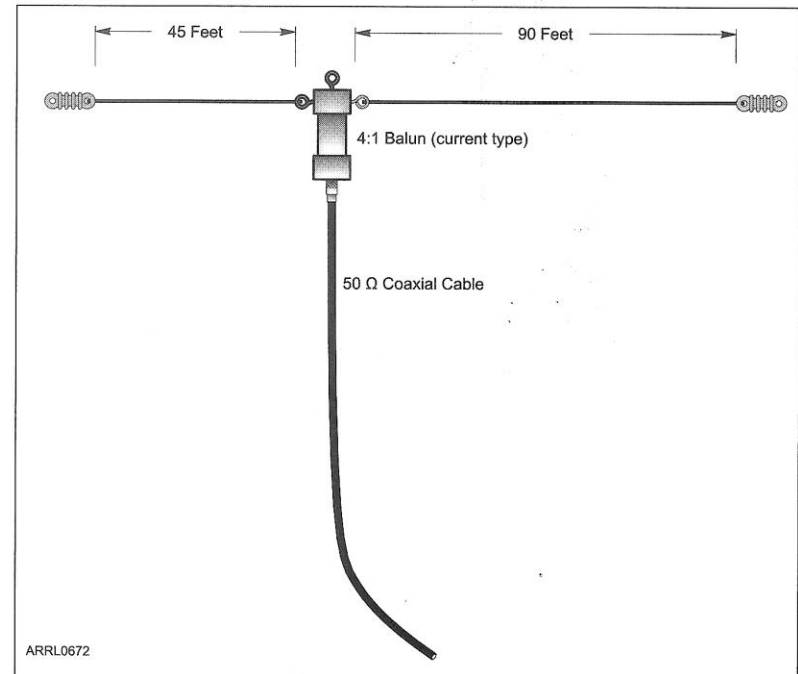
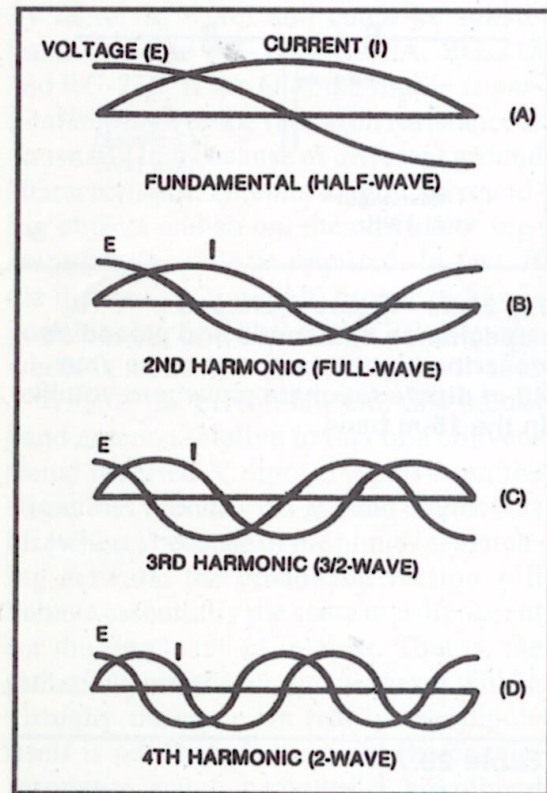

Figure 3.16 — In this example, we have an 80-meter Off Center Fed dipole with the feed point at  $\frac{1}{3}$  wavelength from the end.

# Wire Dipoles – Hide the feed line next to house, gutter or along a tree trunk

## Center Fed

## Off Center Fed

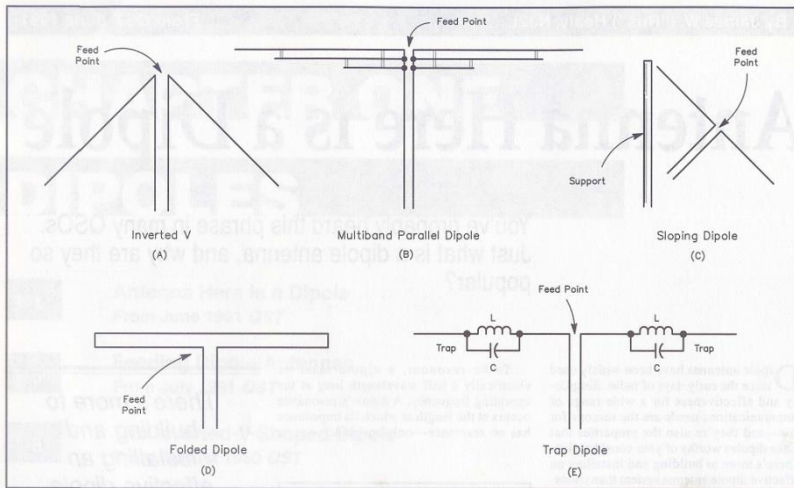
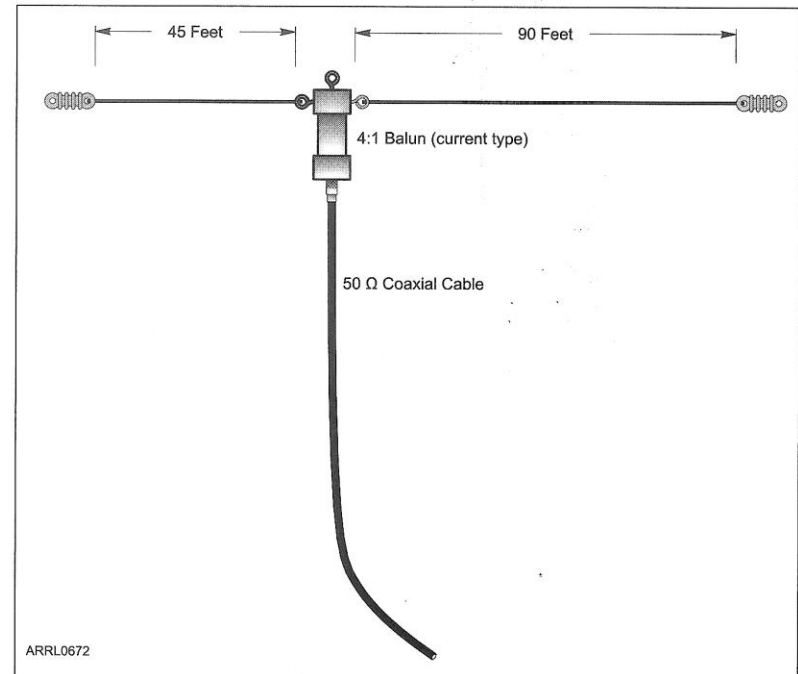

Fig 2—Variations on the dipole are numerous: at A, an inverted V; at B, a multiband parallel dipole; at C, a sloping dipole (sloper); at D, a folded dipole, and at E, a trap dipole. Dipoles of the multiband parallel, trap and folded varieties can be installed in sloping or inverted-V configurations.



ARRL0672

Figure 3.16 — In this example, we have an 80-meter Off Center Fed dipole with the feed point at  $\frac{1}{4}$  wavelength from the end.

# Multiband (wavelength) Loops

(hide the window feed line along a tree or etc.)

Keep Window Feedline Hidden

Find the antenna among the trees

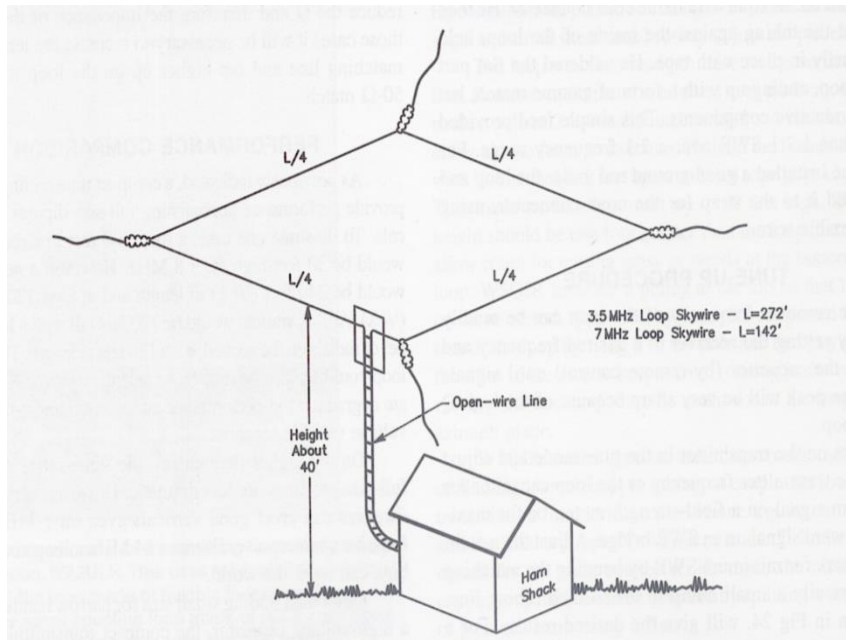

# Room Dipoles

## Room Dipole

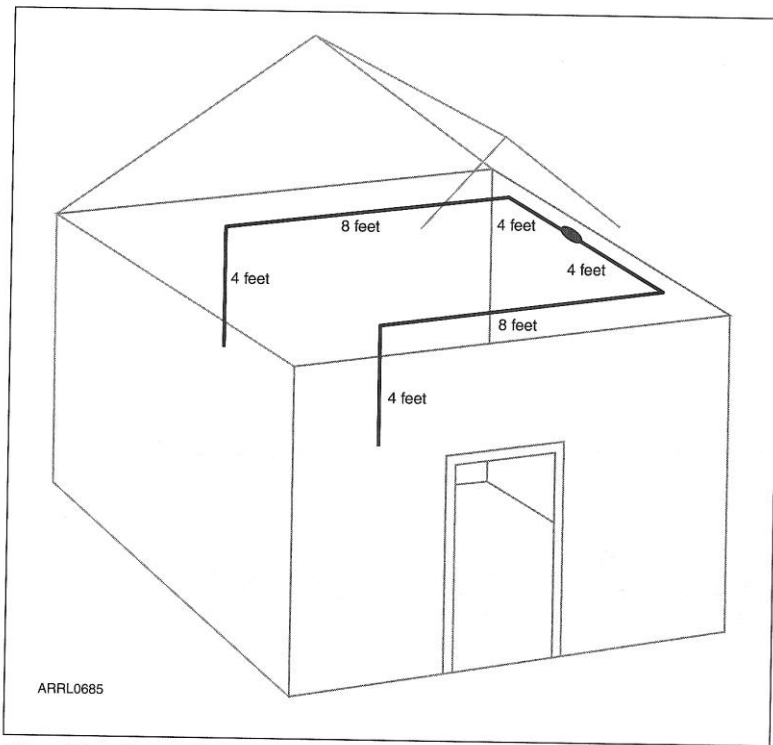

## Room Fan Dipole

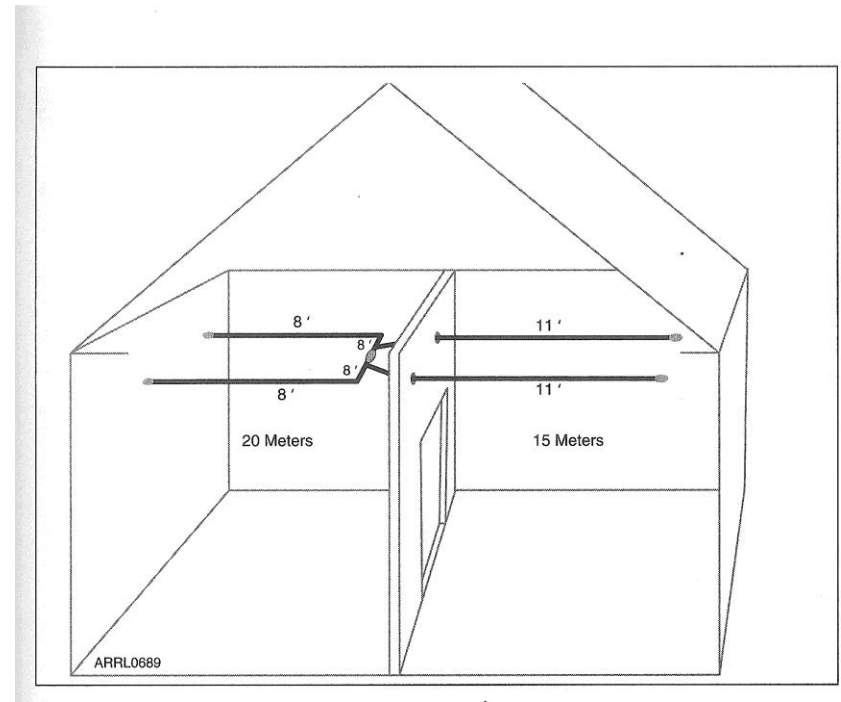

Figure 2.1 — Even a dipole antenna for the 20 meter band can fit into a small room with a bit of folding.

# Keep it in the Attic

## Multi-band Loop

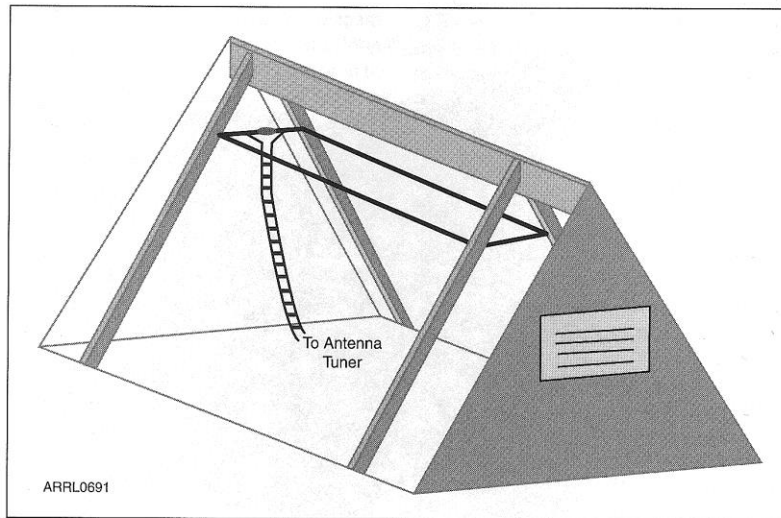

Figure 2.11 — An HF loop antenna can be easily installed within an attic by stringing the wire along the rafters. You can feed it with 450- $\Omega$  ladder line and use an antenna tuner for multiband operation.

## Fixed Wire Beam

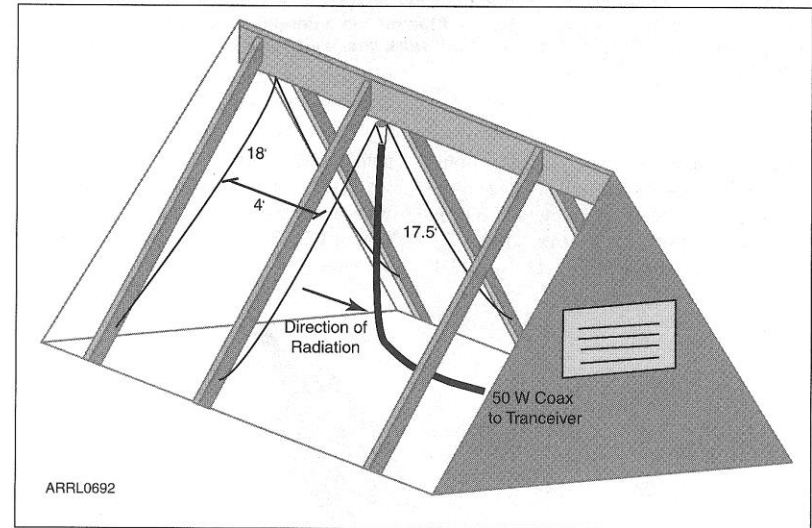

Figure 2.12 — If you have a sufficiently large attic, you can even construct a wire Yagi antenna by using rafters as supports. This example is a 10-meter version. Dimensions shown are approximate.



# Put it in the Attic

Fan Dipole



UHF-VHF Beam



# Verticals = Half a Dipole

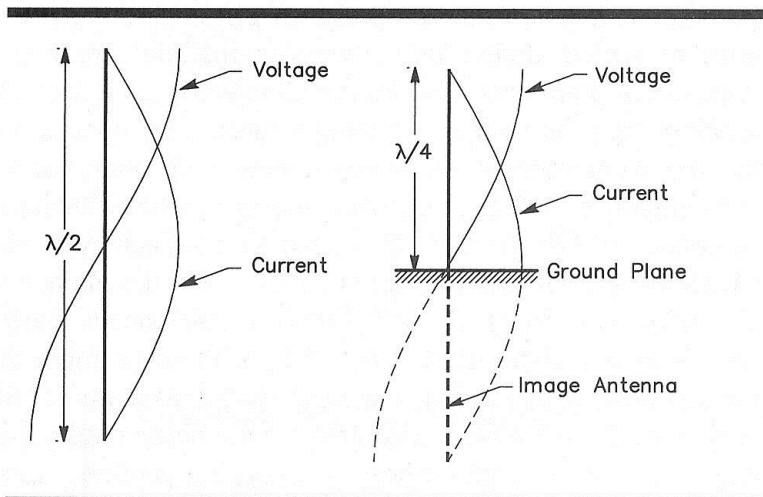
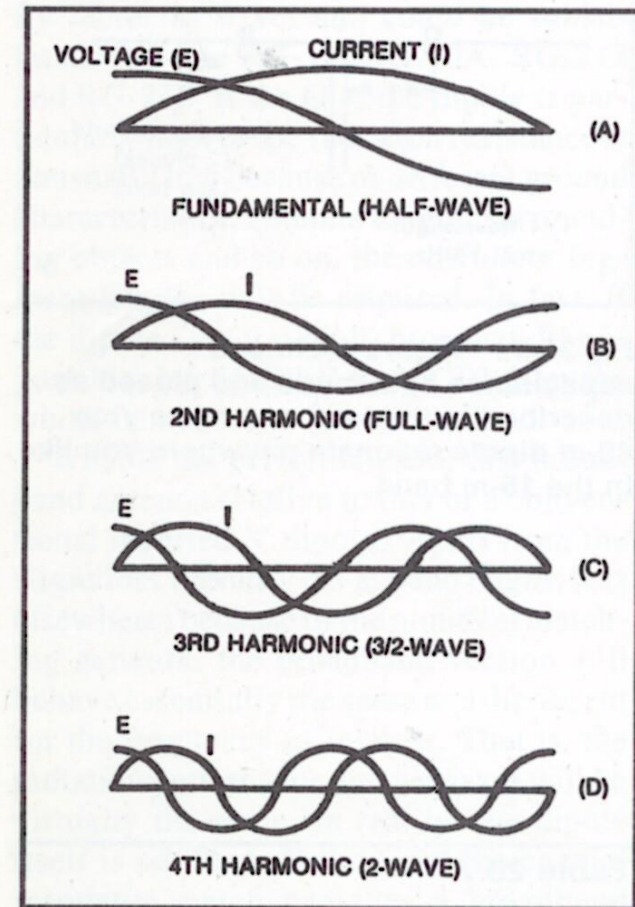

Fig 21—The  $\lambda/2$  dipole antenna and its  $\lambda/4$  ground-plane counterpart. The “missing” quarter wavelength is supplied as an image in “perfect” (that is, high-conductivity) ground.

2-16 Chapter 2



# Stealth is in how you look at it!



# Shortened Vertical (Screwdriver) Antenna



# Multiband Stealth Verticals

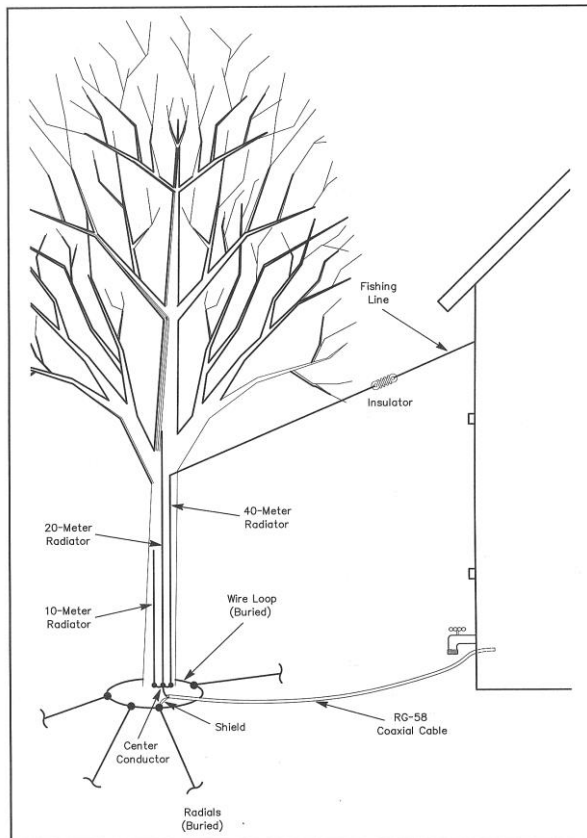

Fig 1—Run the three antenna wires along the trunk and then, if necessary, bend them along the branches. My 40-meter wire is so long that it leaves the tree altogether and attaches to my window frame. Use at least six radials for your ground system, more if you have the space and the patience to place them beneath the soil.



# Restoration of HT-18 Vertical



Once restored and “camo” applied  
it’s time to dig a hole.



# Then it's time to mix concrete.





# Then it's time to invite your grandson for dinner.



# The base and antenna are complete



# An SWR analysis is a good thing.

© 4/20

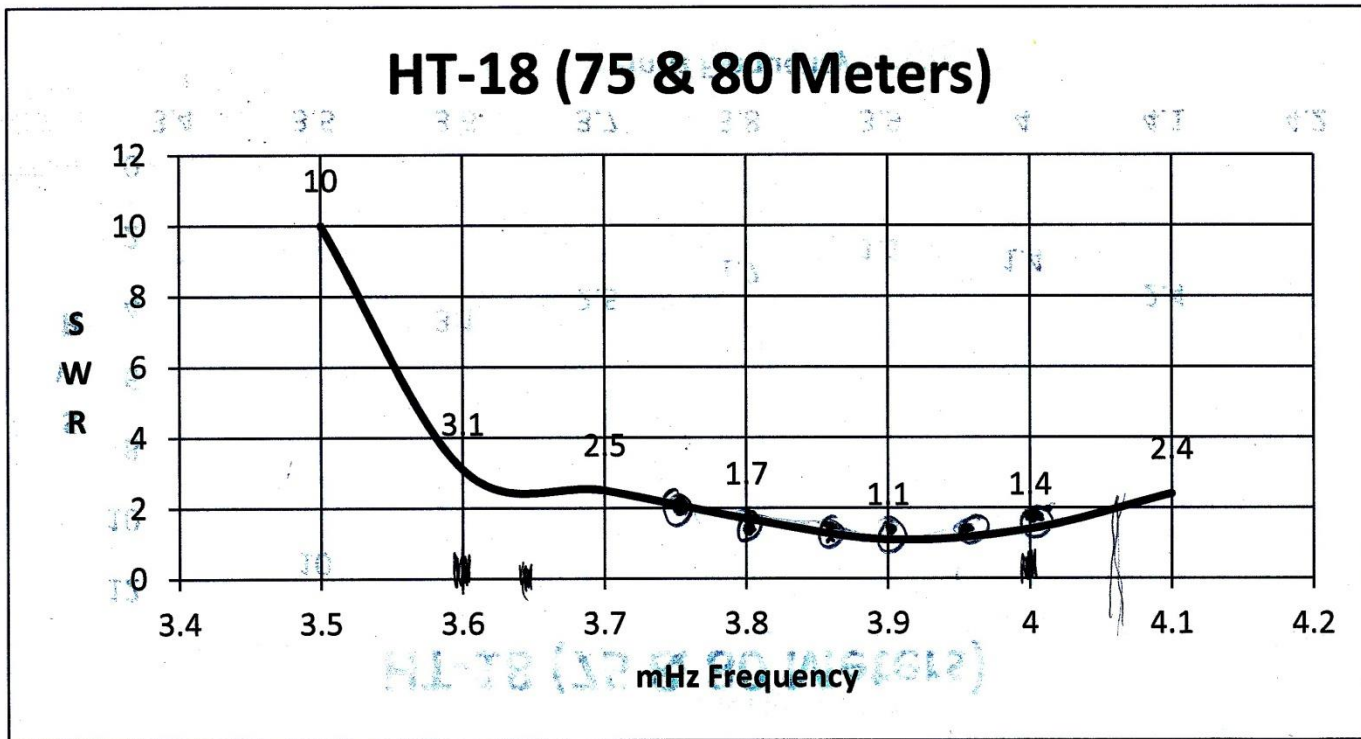

# So where is the HT-18?



# **Stealth ? It means the neighbors don't notice it.**

- Usually a wire on HF or
- Could be a beam on VHF & UHF
- May be a dual purpose radiator or
- May be too small to be noticed or
- May be inside the house or
- May be camouflaged or
- May simply be “out of sight”
- Ideally will be multiband

# Wire & Stealth Antenna

Ozaukee Radio Club

Tom Ruhlmann (W9IPR)